



**JOB
JON**

**PORTABLE
SOLUTIONS**

**JOB
JON**

PORTABLE SOLUTIONS

**JOB
JON**

PORTABLE SOLUTIONS

**100 SERIES
SELF-CONTAINED
PORTABLE LAVATORIES**

Product Overview

JobJon Portable Solutions presents the 100S/W, our approach to contemporary washroom solutions. As events like outdoor concerts, conferences, and festivals shift away from multi-stall lavatories and portable restrooms, and as urban construction sites demand smaller footprints with limited trailer space, the 100S/W emerges as the solution. Designed for scenarios where connecting to sewer and water services is a challenge, this product ensures modern conveniences for teams everywhere. The 100S/W also boasts an exclusive skid option, for easy accessibility by forklift.

Key Features:

- The 100S/W boasts an impressive 118 gallons of fresh water, and 120 gallons of sewage capacity, eliminating the need for on-site services or additional water/sewage tanks.
- Complements your existing site modules by offering a private toilet stall complete with standard washroom amenities such as mirrors, sinks, and paper towel dispensers.
- For larger sites, the 100S/W is also available in various larger layouts.
- Facilitates easy drop off and setup
- Includes built-in, fold-down stairs
- Ensures sanitation with a fully-loaded below-counter HOT WATER system.
- Compact and rugged in design, measuring 5' x 5' 8".
- Powered by 120V 15 AMP for convenience.
- Simple setup, maintenance, and winterization procedures.
- Equipped with heating and heat tracing capabilities to withstand harsh northern winters.

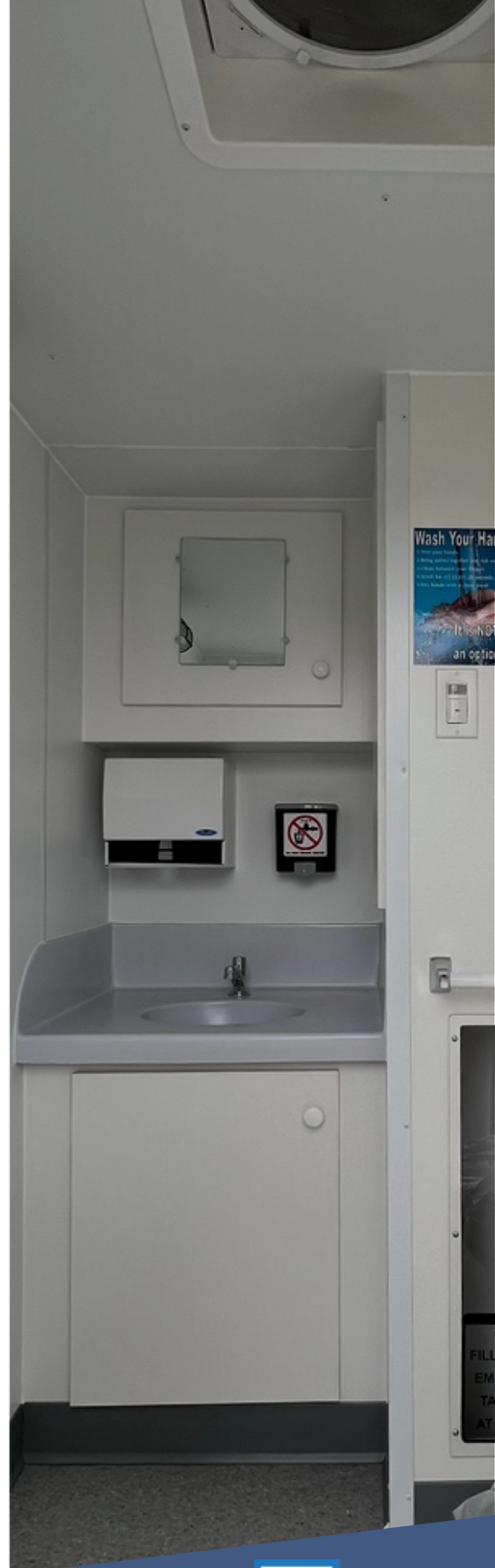



JobJon's Self-Contained 100 series washrooms offer immaculate spaces that cater to your business needs and destinations with utmost cleanliness and convenience.

FLOOR PLAN

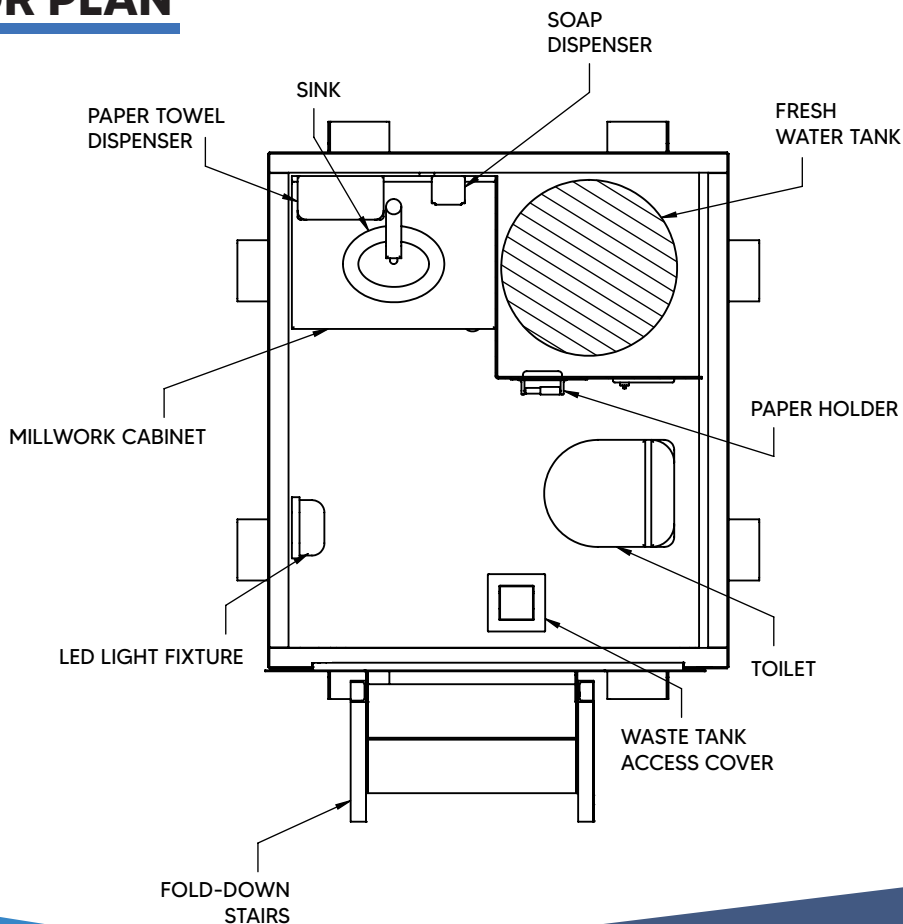

ELEVATIONS

LEFT VIEW

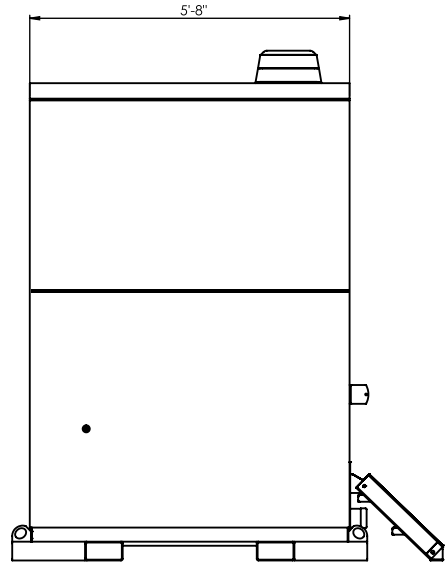

RIGHT VIEW

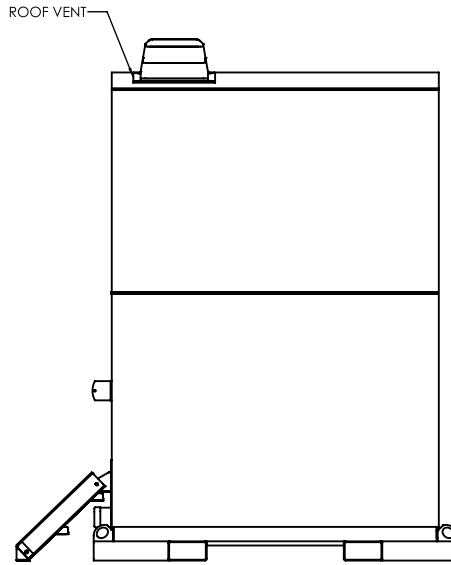

FRONT VIEW

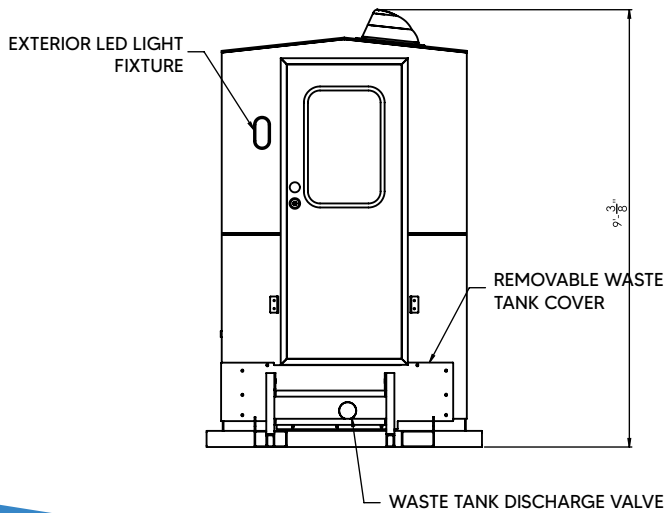

REAR VIEW

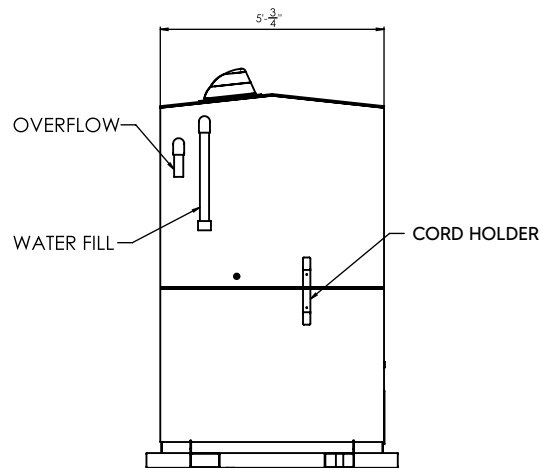

ELECTRICAL

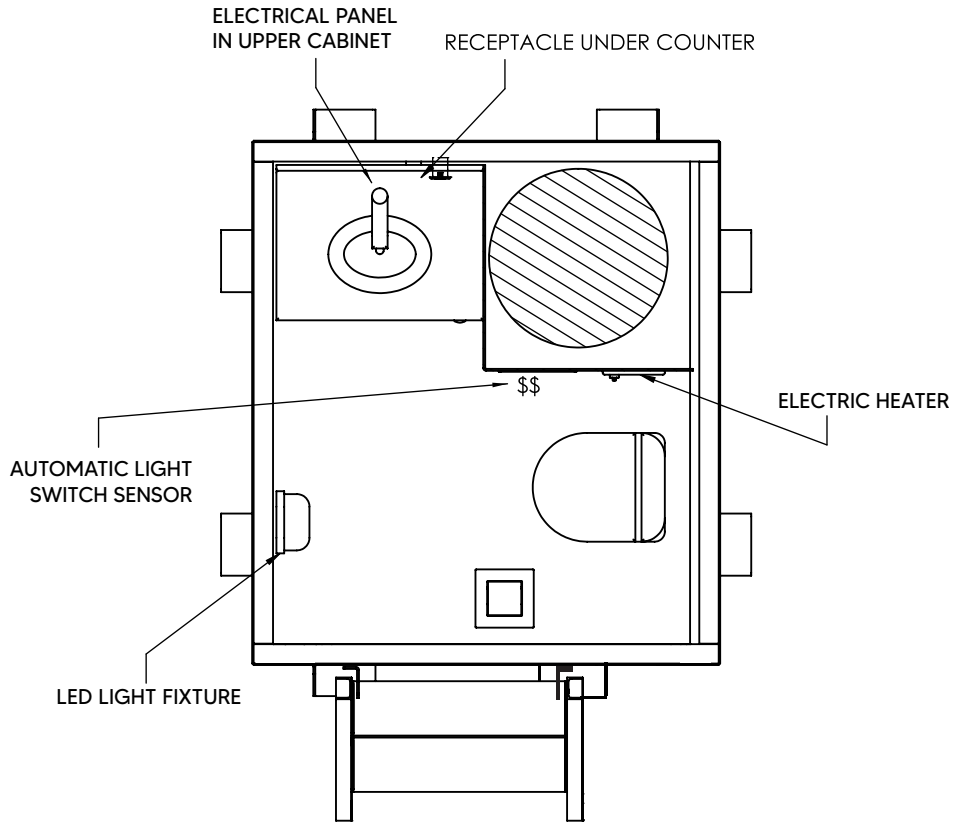

MECHANICAL

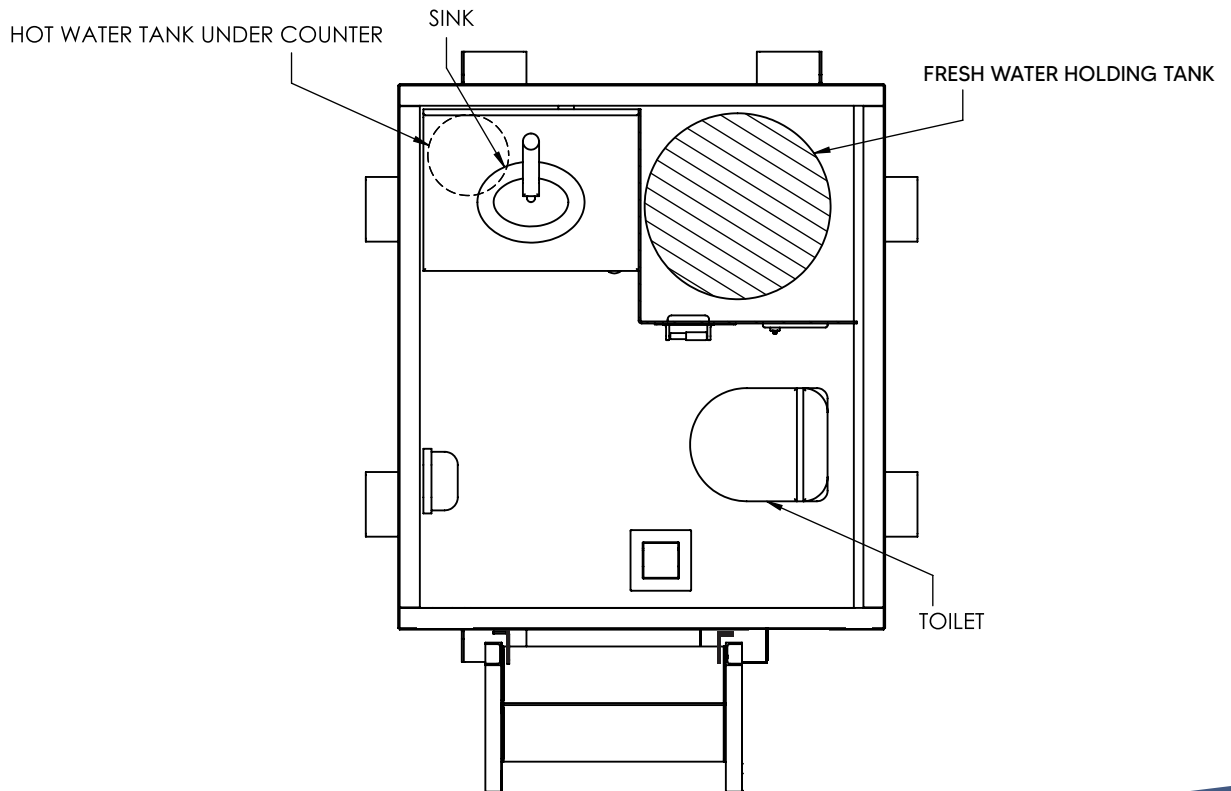



PORTABLE SOLUTIONS

735 ROBLIN BLVD. E, R6W 0N2
Canadian Clients: (204) 502-1933
USA Clients: 1-701-433-9002

