



**PORTABLE  
SOLUTIONS**



# **400 SERIES SELF-CONTAINED PORTABLE LAVATORIES**

## Product Overview

The 400W is JobJon Portable Solutions' innovative response to evolving demands in the realm of temporary restroom solutions. As urban work sites increasingly call for reduced footprints and limited space for construction trailers, and major public events such as outdoor concerts, conferences, or festivals steer away from multi-stall lavatories and portable toilets, the 400W steps in to meet these challenges head-on. Even in scenarios where access to sewer and water services poses a significant hurdle, the 400W can be effortlessly deployed to provide your team with the modern conveniences they've grown accustomed to.

### Key Features:

- Compact and rugged in design, measuring 6' x 20'.
- Includes built-in fold-down stairs and railings.
- Facilitates easy drop off and setup.
- The 400W boasts an impressive 472 gallons of fresh water, and 480 gallons of sewage capacity, eliminating the need for on-site services or additional water/sewage tanks.
- Equipped with a 2 5/16" Ball Hitch.
- Powered by 240 Volt, 70 AMP for convenience.
- Simple setup, maintenance, and winterization procedures.
- Ensures sanitation with a fully-loaded below-counter HOT WATER system.
- Complements your existing site modules by offering four private toilet stalls complete with standard restroom amenities such as mirrors, sinks, and paper towel dispensers.
- Equipped with heating and heat tracing capabilities to withstand harsh northern winters.





**JobJon's Self-Contained 400 series washrooms offer immaculate spaces that cater to your business needs and destinations with utmost cleanliness and convenience.**

## **FLOOR PLAN**

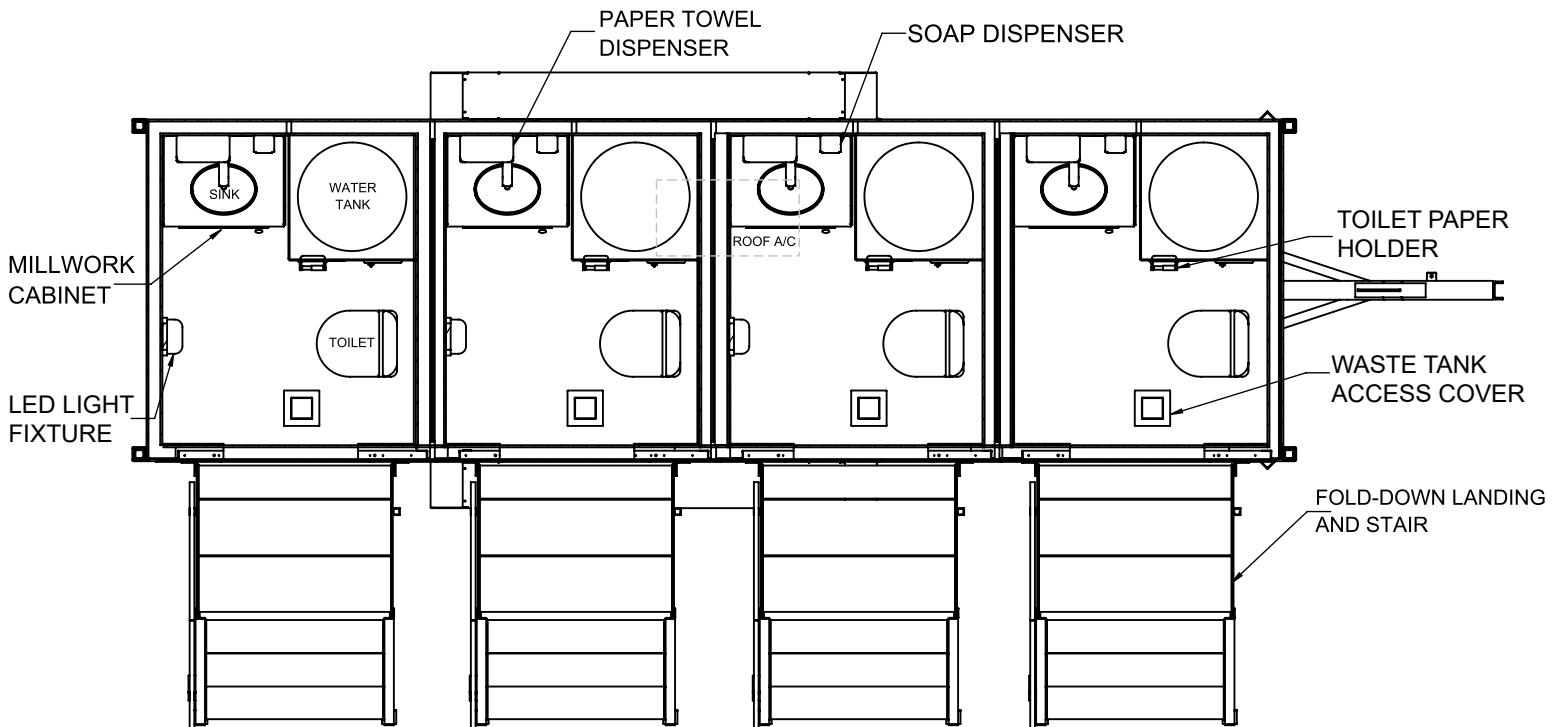

# EXTERIOR VIEW

LEFT VIEW

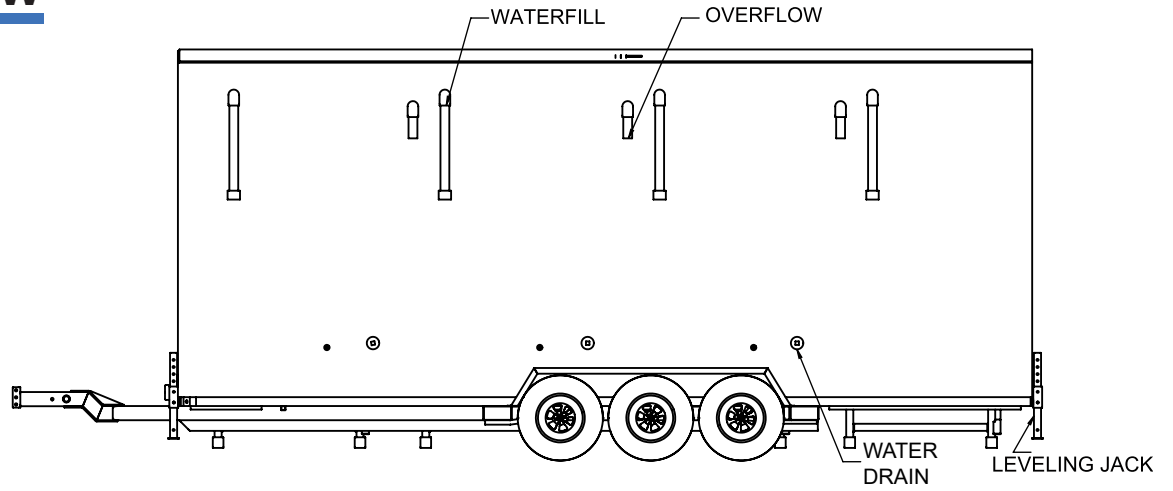

RIGHT VIEW

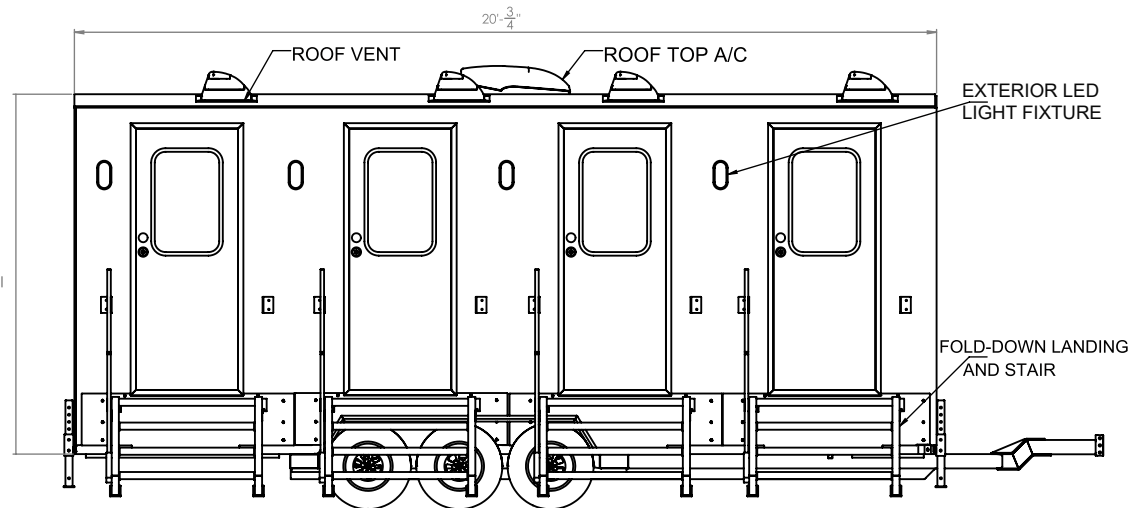

FRONT VIEW

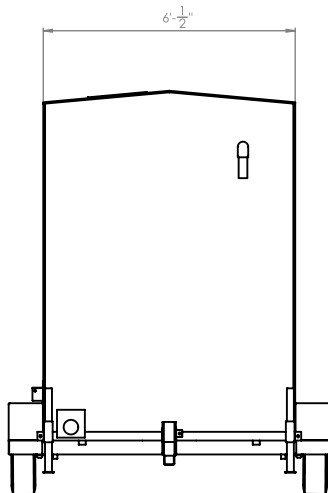

REAR VIEW

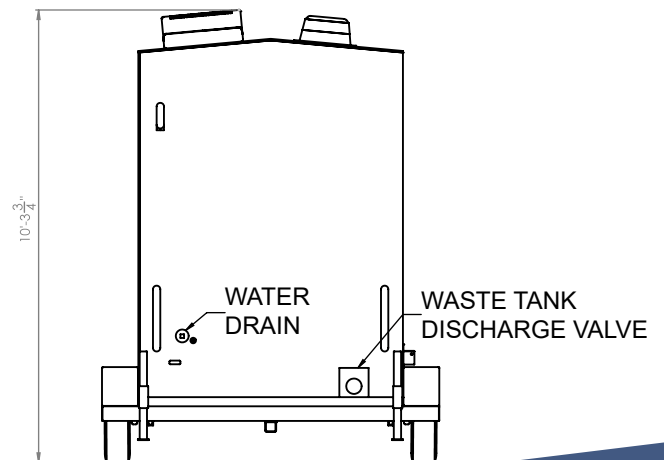

# ELECTRICAL

ELECTRICAL PANEL IN UPPER CABINET

HOT WATER TANK UNDER COUNTER

SINK

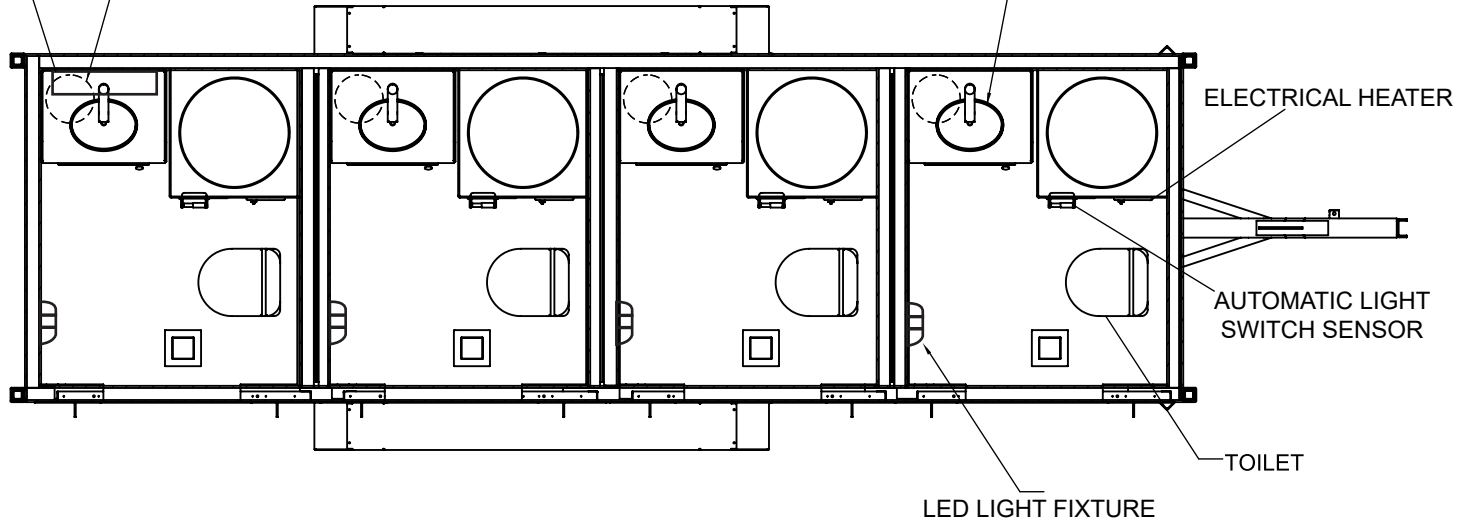

# MECHANICAL

HOT WATER TANK UNDER COUNTER

WATER HOLDING TANK

SINK

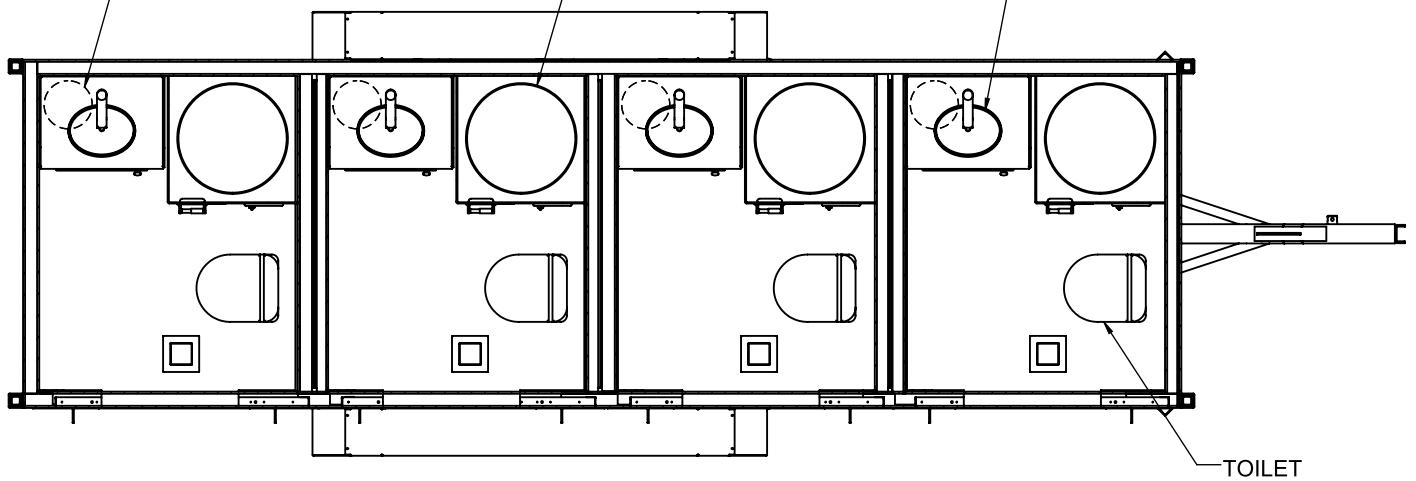

# FOLD-DOWN LANDING AND STAIRS

TOP VIEW

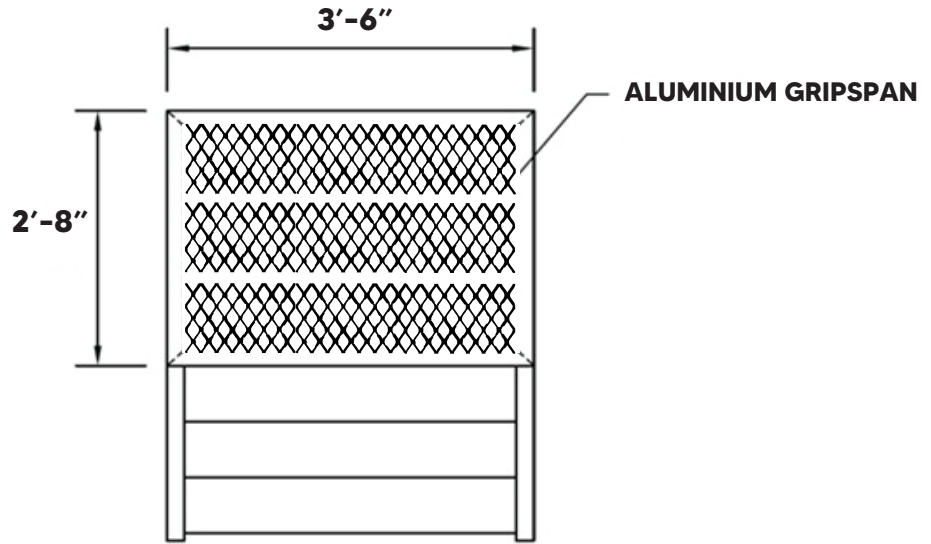

FRONT VIEW

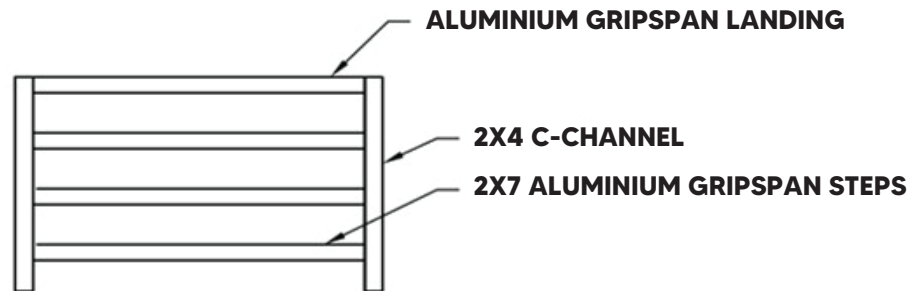

SIDE VIEW

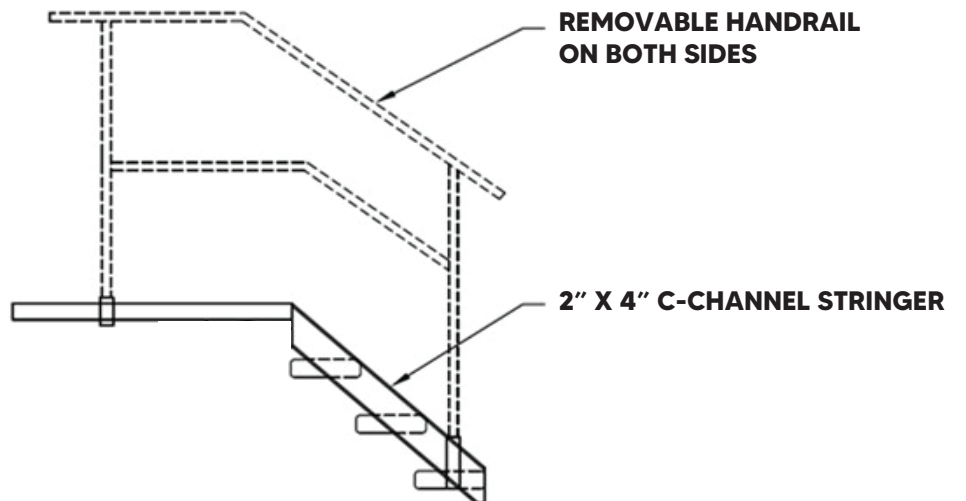







# PORTABLE SOLUTIONS

735 ROBLIN BLVD. E, R6W 0N2  
**Canadian Clients:** (204) 502-1933  
**USA Clients:** 1-701-433-9002

